

Recognized globally
for our quality,
service and the
ability to deliver!

ISO 9001:2008

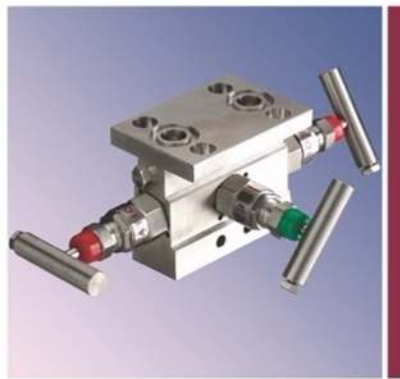
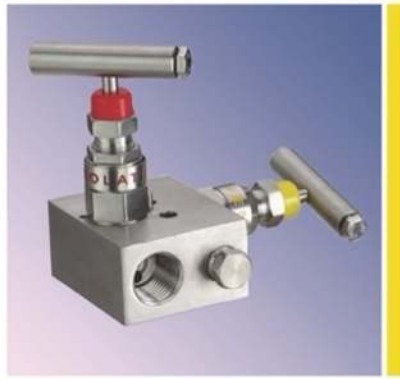
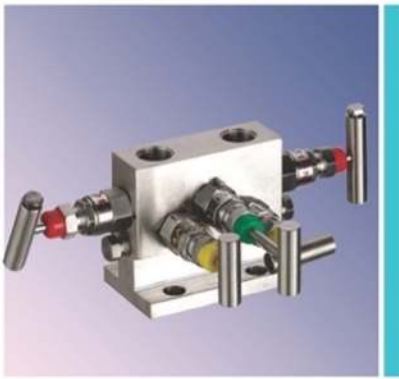

STI MANUFACTURING, INC.
936.856.5541 www.stimfg.com

Introduction Page 3

Part Number Reference Chart Page 4-5

2 Valve Manifolds Page 6-7



3 Valve Manifolds Page 8-10



5 Valve Manifolds Page 11-14



Materials & Testing Page 15-16

Determine the part you need with the Part Number Reference Chart, then email to sales@stimfg.com, or info@stimfg.com, or call 936-856-5541. We will be glad to help you with your Request.



INSTRUMENT MANIFOLDS

MAC-WELD 2, 3 and 5 Valve Manifolds are designed and tested to industry quality standards.

2 Valve Manifolds

Mac -Weld 2 valve manifolds provide economical and convenient mounting of gauge and absolute pressure transmitters and pressure switches. Mac-Weld 2 valve manifolds are offered in direct mount and remote mount configurations.

3 and 5 Valve Manifolds

Mac-Weld 3 and 5 valve manifolds are economical and convenient for mounting differential pressure transmitters and differential pressure switches. Mac-Weld 3 and 5 valve manifolds are available in direct mount and remote mount configurations.

Specifications and Features

Mac-Weld 2, 3, and 5 valve manifolds incorporate high quality needle valves designed to operate at pressures up to 6000 psig with standard PTFE gland packing. The packing is positioned below the stem threads to ensure no contact between system process and the stem threads. The upper gland body is tightened and secured into position by a lock nut. The lower gland body is directly screwed into the component body and secured into place to prevent accidental loosening of the gland body during operation. Additionally:

- Standard seat diameter - 5mm CV: 0.4
- Maximum standard pressure up to 6000 psig @ 100° F (414 barg @ 38° C)
- Stainless steel pin prevents loosening of the gland body during operation
- Gland is externally adjustable
- Backseat stop spindle prevents blowout
- Non-rotating trim enables the spindle to self center with the orifice for bubble tight shut-off
- Dust cap prevents ingress of contaminants

Please refer to the following pages to reference Instrument Manifold Configuration and sizes.

Part Number Reference Chart

Part Number	SM-5T-L-DM-08F-FLG-P		
Component	SM	Manifold	
No. Valves	2	2 Valve Manifold	
	3	3 Valve Manifold	
	5	5 Valve Manifold	
Model	BB	Block & Bleed	
	# (2,3,5)	Bar Type	
	C	Horizontal	
	T	T Type	
	H	H Type	
Body Material	SS	316 Stainless Steel	
	L	316L Stainless Steel	
Mounting	DM	Direct Mount	
	RM	Remote Mount	
Process Connection (Inlet)	08F	½" Female NPT (Threads to ASME B1.20.10)	
	08M	½" Male NPT (Threads to ASME B1.20.10)	
	FLG	Flange	
Instrument Connection (Outlet)	08F	½" Female NPT (Threads to ASME B1.20.10)	
	08M	½" Male NPT (Threads to ASME B1.20.10)	
	FLG	Flange	
Drain c/w Plug	P	¼" Female NPT	
	PB	¼" Female NPT Bottom	
Vent	V08F	½" Female NPT	
	V04F	¼" Female NPT	

A Note on Safe Product Selection:

Customer to select suitable product type and size based on the application considering the overall system design.

For Safe, easy and trouble-free operation the customer must consider material compatibility, temperature and pressure ratings when selecting a product.



Part Number Reference Chart

Part Number	SM-5T-L-DM-08F-FLG-P			
Component	SM	Manifold		
No. Valves	2	2 Valve Manifold		
	3	3 Valve Manifold		
	5	5 Valve Manifold		
Model	GV	Gauge Valve		
	BB	Block & Bleed		
	# (2,3,5)	Bar Type		
	C	Horizontal		
	T	T Type		
	H	H Type		
Body Material	SS	316 Stainless Steel		
	L	316L Stainless Steel		
Mounting	DM	Direct Mount		
	RM	Remote Mount		
Process Connection (Inlet)	08F	½" Female NPT (Threads to ASME B1.20.10)		
	08M	½" Male NPT (Threads to ASME B1.20.10)		
	FLG	Flange		
Instrument Connection (Outlet)	08F	½" Female NPT (Threads to ASME B1.20.10)		
	08M	½" Male NPT (Threads to ASME B1.20.10)		
	FLG	Flange		
Drain c/w Plug	P	¼" Female NPT		
	PB	¼" Female NPT Bottom		
Vent	V08F	½" Female NPT		
	V04F	¼" Female NPT		

Please Note the following:

Part Number Reference Chart is provided for informational purposes only. Mac-Weld provides standard stock items with predetermined part numbers for your convenience.

A Note on Safe Product Selection:

Customer to select suitable product type and size based on the application considering the overall system design.

For Safe, easy and trouble-free operation the customer must consider material compatibility, temperature and pressure ratings when selecting a product.

2 - Valve Manifold
Remote Mount with Drain

Mac-Weld 2 - Valve remote mount manifold provides block and bleed with drain/vent for pressure gauge, switch or transmitter applications.

- 316L Stainless Steel Body, stem and trim
- 6000 psig @ 100° F (414 bar @ 38° C)
- PTFE Packing
- Non-rotating trim provides bubble tight shut-off
- Optional availability: NACE certified wetted parts and graphoil packing



PART NUMBER				
SM-2C-L-RM-08F-08F-P				
MANIFOLD TYPE AND DESCRIPTION	END CONNECTION		DRAIN / VENT c/w PLUG	MATERIAL
	PROCESS (Inlet)	INSTRUMENT (Outlet)		
Stainless Steel 2 Valve Block & Bleed, Remote mount, T-Bar handle, c/w Drain/Vent	½" Female NPT	½" Female NPT	¼" Female NPT	316L

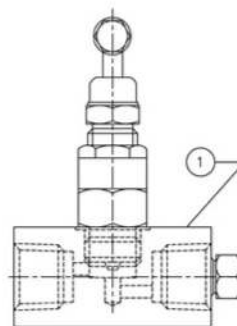
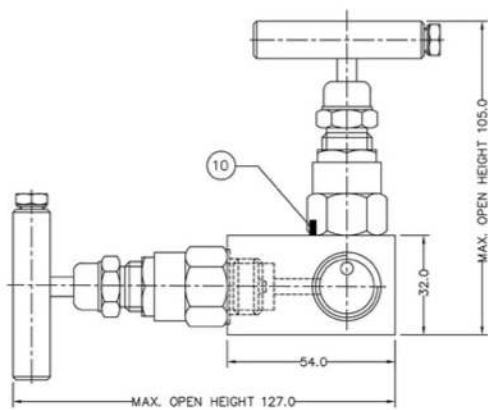
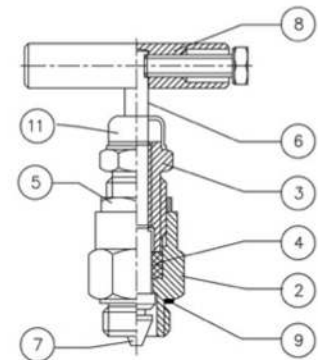
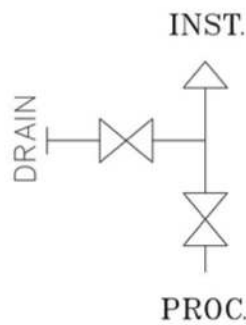
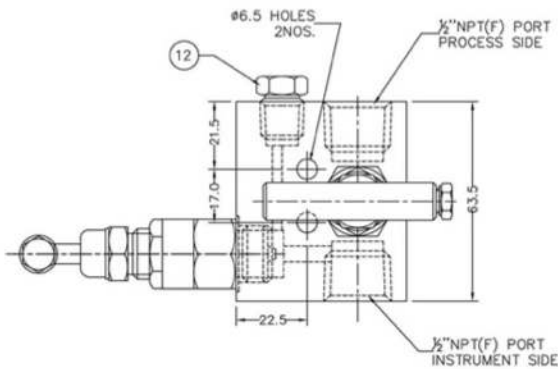

PART NO.	PART DESCRIPTION	MATERIAL	QTY
1	BODY	SS 316L	1
2	GLAND BODY	SS 316L	2
3	GLAND RETAINER	SS 304	2
4	GLAND SEAL	P.T.F.E	4
5	CHECK NUT	SS 304	2
6	SPINDLE	SS 316L	2
7	TRIM	SS 316L	2
8	HANDLE	SS 304	2
9	WASHER	S.S.	2
10	LOCK PIN	SS 304	2
11	DUST CAP	P.V.C.	2
12	DRAIN PLUG ¼" NPT (M)	SS 316L	1

GV 2 - Valve Manifold
Direct Mount with Drain

Mac-Weld's GV 2 - Valve Manifold directly mounts to in-line gauge or static instruments to provide single block and bleed for isolation and drain/vent capability.

- 316L Stainless Steel Body, stem and trim
- 6000 psig @ 100° F (414 bar @ 38° C)
- PTFE Packing
- Non-rotating trim provides bubble tight shut-off
- Optional availability: NACE certified wetted parts and graphoil packing



PART NUMBER				
SM-2GV-L-DM-08M-08F-P				
MANIFOLD TYPE AND DESCRIPTION	END CONNECTION		DRAIN / VENT c/w PLUG	MATERIAL
	PROCESS (Inlet)	INSTRUMENT (Outlet)		
Stainless Steel 2 Valve Block & Bleed In-Line style, direct mount, T-Bar handle, c/w Drain/Vent	½" Male NPT	½" Female NPT	¼" Female NPT	316L

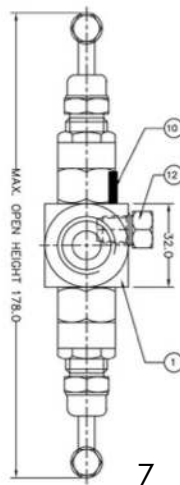
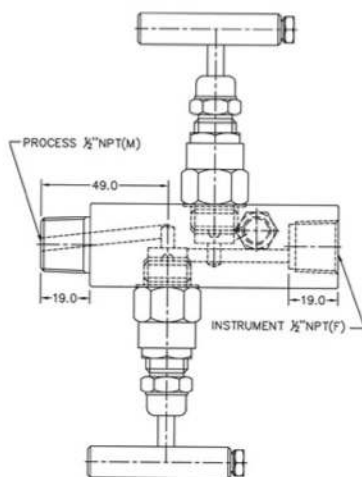
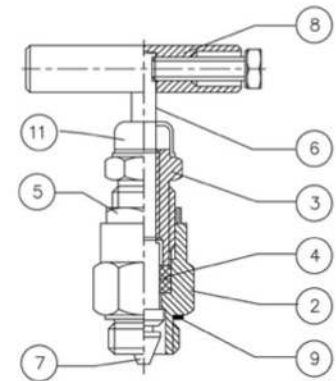
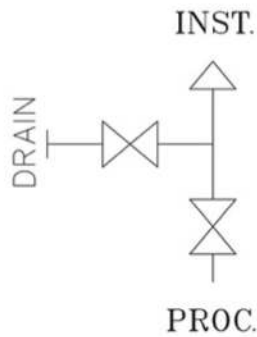
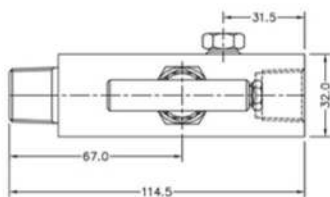

PART NO.	PART DESCRIPTION	MATERIAL	QTY
1	BODY	SS 316L	1
2	GLAND BODY	SS 316L	2
3	GLAND RETAINER	SS 304	2
4	GLAND SEAL	P.T.F.E	4
5	CHECK NUT	SS 304	2
6	SPINDLE	SS 316L	2
7	TRIM	SS 316L	2
8	HANDLE	SS 304	2
9	WASHER	S.S.	2
10	LOCK PIN	SS 304	2
11	DUST CAP	P.V.C.	2
12	DRAIN PLUG ¼" NPT (M)	SS 316L	1

3-Valve In-Line Block & Bleed Manifold

Remote Mount with Vent

Mac-Weld's 3 - Valve In-Line Block and Bleed manifold is a variation of a typical 2 valve block and bleed manifold for gauge and static instrument applications. An additional block valve is provided as well as a single 1/2" vent/drain port located on the underside of the manifold.



- 316L Stainless Steel Body, stem and trim
- 6000 psig @ 100° F (414 bar @ 38° C)
- PTFE Packing
- Non-rotating trim provides bubble tight shut-off
- Optional availability: NACE certified wetted parts and graphoil packing

PART NUMBER				
SM-3BB-L-RM-08F-08F-V08F				
MANIFOLD TYPE AND DESCRIPTION	END CONNECTION		DRAIN / VENT c/w PLUG	MATERIAL
	PROCESS (Inlet)	INSTRUMENT (Outlet)		
Stainless Steel 3 Valve Block and Bleed In-Line Manifold, Remote mount, T-Bar handle, c/w Vent/Drain	1/2" Female NPT	1/2" Female NPT	1/2" Female NPT	316L

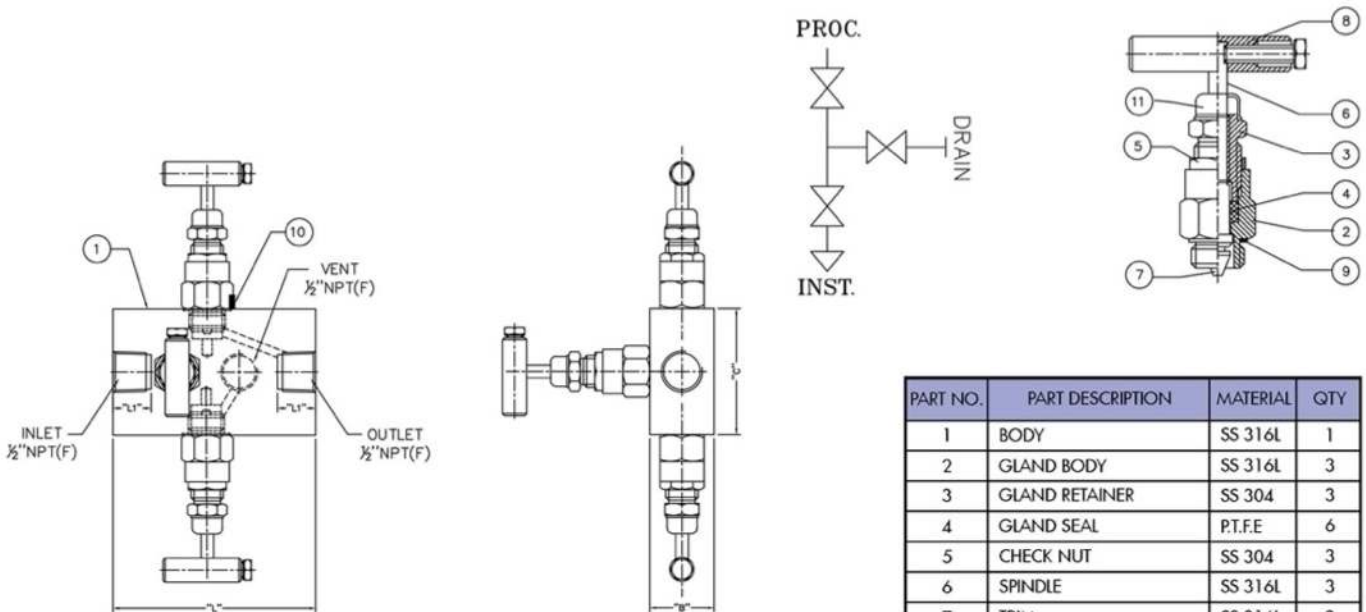

PART NO.	PART DESCRIPTION	MATERIAL	QTY
1	BODY	SS 316L	1
2	GLAND BODY	SS 316L	3
3	GLAND RETAINER	SS 304	3
4	GLAND SEAL	P.T.F.E	6
5	CHECK NUT	SS 304	3
6	SPINDLE	SS 316L	3
7	TRIM	SS 316L	3
8	HANDLE	SS 304	3
9	WASHER	S.S.	3
10	LOCK PIN	SS 304	3
11	DUST CAP	P.V.C.	3

3 - Valve Manifold
Remote Mount with Drain

Mac-Weld's 3-Valve Remote Mount Manifold with drain/vent for differential pressure instrumentation. The manifold has one equalizer valve, two isolation valves and two drain/vent ports.

- 316L Stainless Steel Body, stem and trim
- 6000 psig @ 100° F (414 bar @ 38° C)
- PTFE Packing
- Non-rotating trim provides bubble tight shut-off
- Optional availability: NACE certified wetted parts and graphoil packing



PART NUMBER				
SM-3C-L-RM-08F-08F-P				
MANIFOLD TYPE AND DESCRIPTION	END CONNECTION		DRAIN / VENT c/w PLUG	MATERIAL
	PROCESS (Inlet)	INSTRUMENT (Outlet)		
Stainless Steel 3 Valve Manifold, Remote mount, T-Bar handle, c/w Drain/Vent	1/2" Female NPT	1/2" Female NPT	1/4" Female NPT	316L

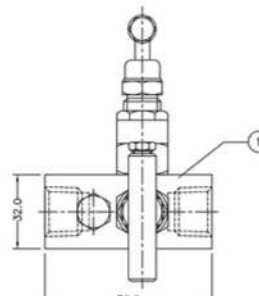
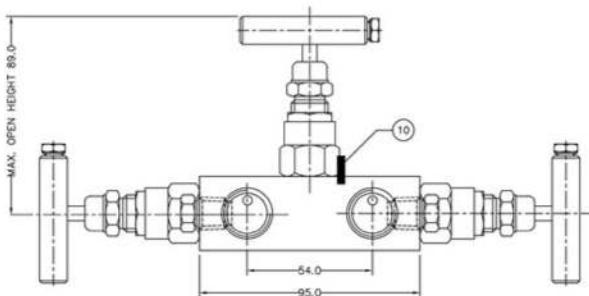
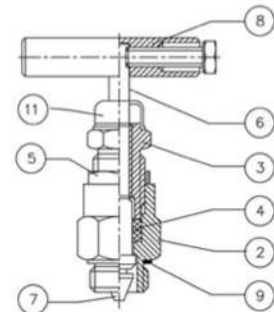
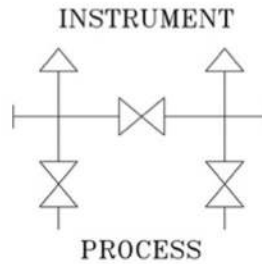
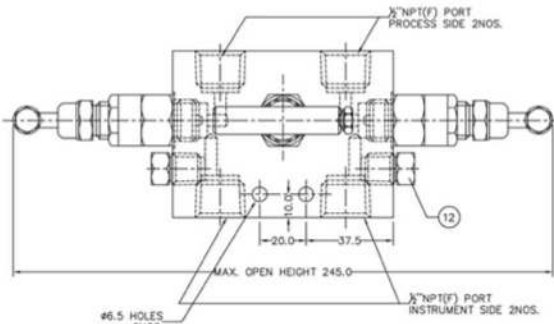

PART NO.	PART DESCRIPTION	MATERIAL	QTY
1	BODY	SS 316L	1
2	GLAND BODY	SS 316L	3
3	GLAND RETAINER	SS 304	3
4	GLAND SEAL	P.T.F.E	6
5	CHECK NUT	SS 304	3
6	SPINDLE	SS 316L	3
7	TRIM	SS 316L	3
8	HANDLE	SS 304	3
9	WASHER	S.S.	3
10	LOCK PIN	SS 304	3
11	DUST CAP	P.V.C.	3
12	DRAIN PLUG 1/4" NPT (F)	SS 316L	2

3 - Valve 'T' Type Manifold
Direct Mount with Drain

Mac-Weld's 3 - Valve Direct Mount 'T' Type Manifold with drain/vent for differential pressure instrumentation. The manifold has one equalizer valve, two isolation valves and two drain/vent ports

- 316L Stainless Steel Body, stem and trim
- 6000 psig @ 100° F (414 bar @ 38° C)
- PTFE Packing
- Non-rotating trim provides bubble tight shut-off
- Optional availability: NACE certified wetted parts and graphoil packing
- Flange O-rings and mounting bolts included with manifold



PART NUMBER				
SM-3T-L-DM-08F-FLG-P				
MANIFOLD TYPE AND DESCRIPTION	END CONNECTION		DRAIN / VENT c/w PLUG	MATERIAL
	PROCESS	INSTRUMENT		
Stainless Steel 3 Valve Manifold, 'T' Type, Direct mount, T-Bar handle, c/w Drain/Vent	(Inlet) 1/2" Female NPT	(Outlet) Flange	1/4" Female NPT	316L

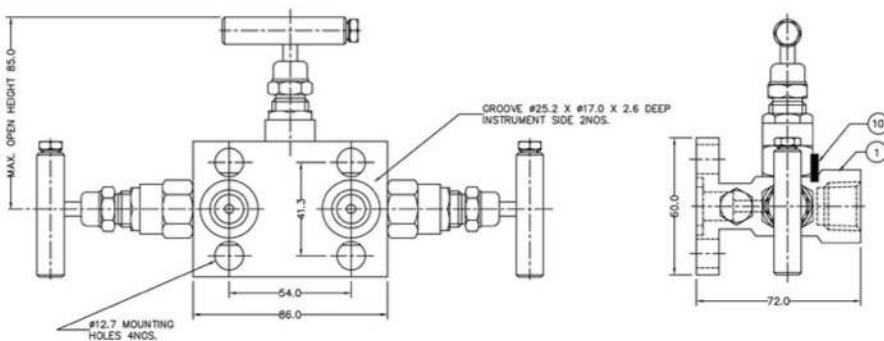
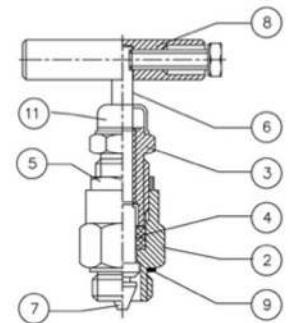
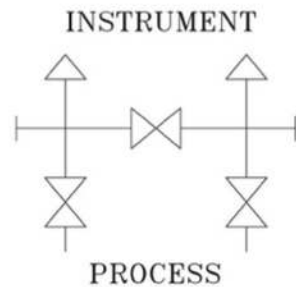
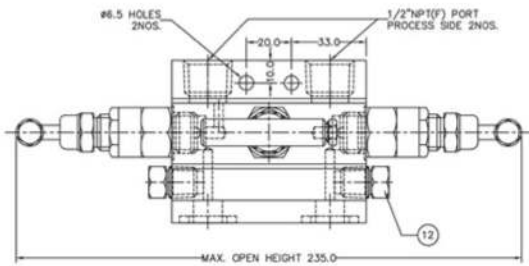

PART NO.	PART DESCRIPTION	MATERIAL	QTY
1	BODY	SS 316L	1
2	GLAND BODY	SS 316L	3
3	GLAND RETAINER	SS 304	3
4	GLAND SEAL	P.T.F.E	6
5	CHECK NUT	SS 304	3
6	SPINDLE	SS 316L	3
7	TRIM	SS 316L	3
8	HANDLE	SS 304	3
9	WASHER	S.S.	3
10	LOCK PIN	SS 304	3
11	DUST CAP	P.V.C.	3
12	DRAIN PLUG 1/4" NPT (F)	SS 316L	2

5 - Valve Manifold
Remote Mount with Drain

Mac-Weld's 5 - Valve Remote Mount Manifold with drain/vent for differential pressure instrumentation. The manifold has one equalizer valve, two isolation valves and two drain/vent ports.



- 316L Stainless Steel Body, stem and trim
- 6000 psig @ 100° F (414 bar @ 38° C)
- PTFE Packing
- Non-rotating trim provides bubble tight shut-off
- Optional availability: NACE certified wetted parts and graphoil packing

PART NUMBER				
SM-5C-L-RM-08F-08F-P				
MANIFOLD TYPE AND DESCRIPTION	END CONNECTION		DRAIN / VENT c/w PLUG	MATERIAL
	PROCESS (Inlet)	INSTRUMENT (Outlet)		
Stainless Steel 5 Valve Manifold, Remote mount, T-Bar handle	1/2" Female NPT	1/2" Female NPT	1/4" Female NPT	316L

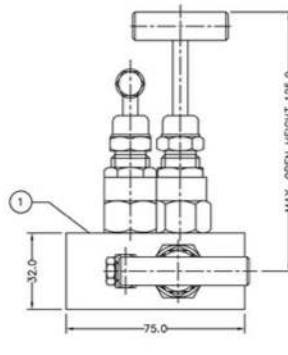
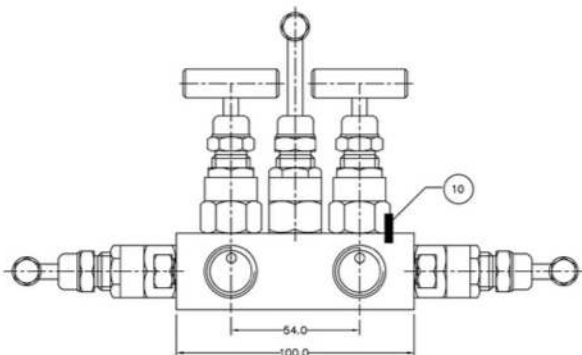
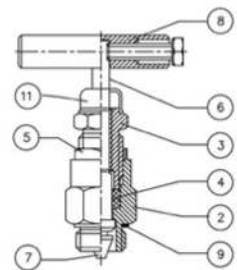
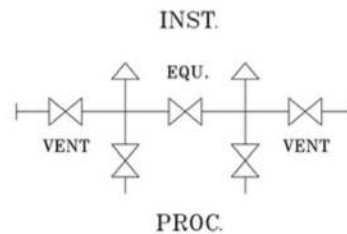
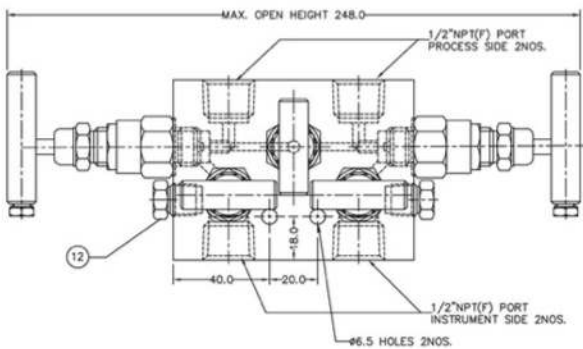

PART NO.	PART DESCRIPTION	MATERIAL	QTY
1	BODY	SS 316L	1
2	GLAND BODY	SS 316L	5
3	GLAND RETAINER	SS 304	5
4	GLAND SEAL	P.T.F.E	10
5	CHECK NUT	SS 304	5
6	SPINDLE	SS 316L	5
7	TRIM	SS 316L	5
8	HANDLE	SS 304	5
9	WASHER	S.S.	5
10	LOCK PIN	SS 304	5
11	DUST CAP	P.V.C.	5
12	DRAIN PLUG 1/4" NPT (F)	SS 316L	2

5 - Valve Bar/ Wafer Type Manifold
Remote Mount with Drain

Mac-Weld's 5 - Valve Bar/Wafer Type remote mount Manifold is designed for differential pressure instrument applications. Standard manifold configuration is one equalizer valve positioned between two isolation valves. Additionally, two drain/vent ports are provided.



- 316L Stainless Steel Body, stem and trim
- 6000 psig @ 100° F (414 bar @ 38° C)
- PTFE Packing
- Non-rotating trim provides bubble tight shut-off
- Optional availability: NACE certified wetted parts and graphoil packing

PART NUMBER				
SM-5-L-RM-08F-08F-P				
MANIFOLD TYPE AND DESCRIPTION	END CONNECTION		DRAIN / VENT c/w PLUG	MATERIAL
	PROCESS	INSTRUMENT		
Stainless Steel 5 Valve Bar/ Wafer Type Manifold, Remote mount, T-Bar handle, c/w Drain/Vent	(Inlet) ½" Female NPT	(Outlet) ½" Female NPT	¼" Female NPT	316L

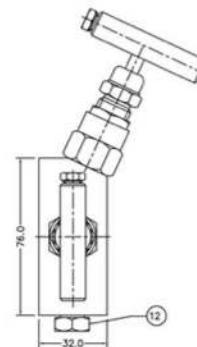
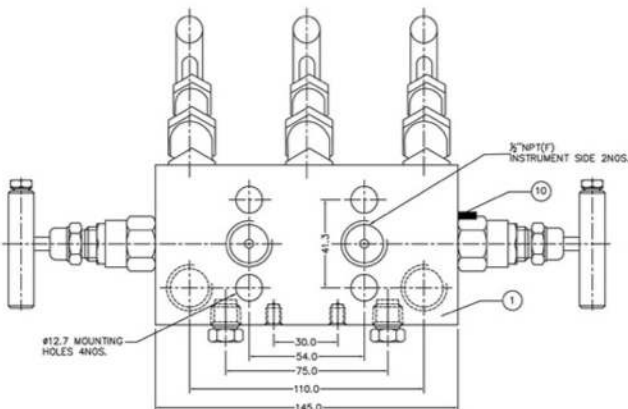
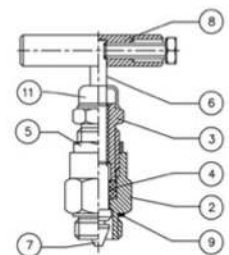
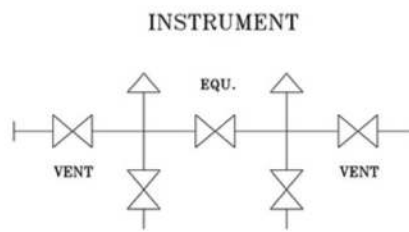
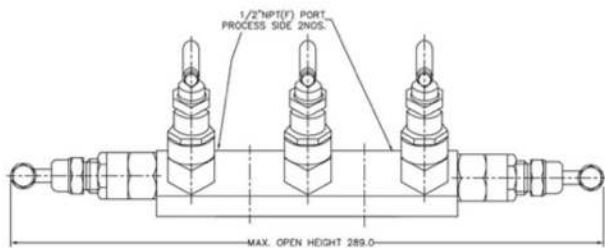

PART NO.	PART DESCRIPTION	MATERIAL	QTY
1	BODY	SS 316L	1
2	GLAND BODY	SS 316L	5
3	GLAND RETAINER	SS 304	5
4	GLAND SEAL	P.T.F.E	10
5	CHECK NUT	SS 304	5
6	SPINDLE	SS 316L	5
7	TRIM	SS 316L	5
8	HANDLE	SS 304	5
9	WASHER	S.S.	5
10	LOCK PIN	SS 304	5
11	DUST CAP	P.V.C.	5
12	DRAIN PLUG ¼" NPT (M)	SS 316L	2

5 - Valve Bar Type Manifold
Direct Mount with Drain

Mac-Weld's 5 - Valve Bar Type Manifold is direct mount for differential pressure instrument applications. Standard manifold configuration is one equalizer valve positioned between two isolation valves. Additionally, two drain/vent ports are provided.

- 316L Stainless Steel Body, stem and trim
- 6000 psig @ 100° F (414 bar @ 38° C)
- PTFE Packing
- Non-rotating trim provides bubble tight shut-off
- Optional availability: NACE certified wetted parts and graphoil packing
- Flange O-rings and mounting bolts included with manifold



PART NUMBER				
SM-5-L-DM-08F-FLG-P				
MANIFOLD TYPE AND DESCRIPTION	END CONNECTION		DRAIN / VENT c/w PLUG	MATERIAL
	PROCESS (Inlet)	INSTRUMENT (Outlet)		
Stainless Steel 5 Valve Bar Type Manifold, Direct mount, T-Bar handle, c/w Drain/Vent	1/2" Female NPT	Flange	1/4" Female NPT	316L

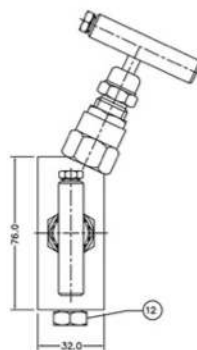
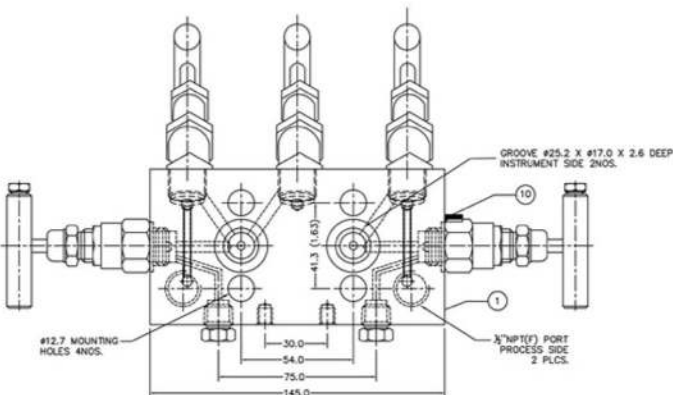
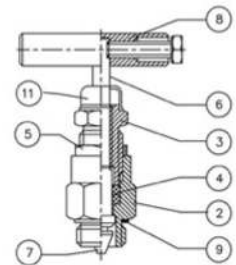
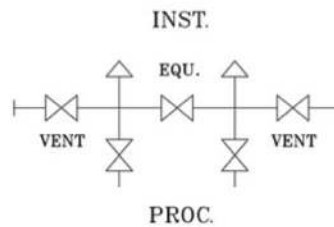
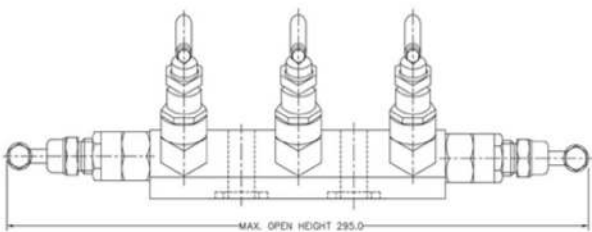

PART NO.	PART DESCRIPTION	MATERIAL	QTY
1	BODY	SS 316L	1
2	GLAND BODY	SS 316L	5
3	GLAND RETAINER	SS 304	5
4	GLAND SEAL	P.T.F.E	10
5	CHECK NUT	SS 304	5
6	SPINDLE	SS 316L	5
7	TRIM	SS 316L	5
8	HANDLE	SS 304	5
9	WASHER	S.S.	5
10	LOCK PIN	SS 304	5
11	DUST CAP	P.V.C.	5
12	DRAIN PLUG 1/4" NPT (M)	SS 316L	2

5 - Valve 'T' Type Manifold
Direct Mount with Drain

Mac-Weld's 5 - Valve Direct Mount 'T' Type Manifold with drain/vent for differential pressure instrumentation. The manifold has one equalizer valve, two isolation valves, two vent valves and drain/vent ports.



- 316L Stainless Steel Body, stem and trim
- 6000 psig @ 100° F (414 bar @ 38° C)
- PTFE Packing
- Non-rotating trim provides bubble tight shut-off
- Optional availability: NACE certified wetted parts and graphoil packing
- Flange O-rings and mounting bolts included with manifold

PART NUMBER				
SM-5T-L-DM-08F-FLG-P				
MANIFOLD TYPE AND DESCRIPTION	END CONNECTION		DRAIN / VENT c/w PLUG	MATERIAL
	PROCESS	INSTRUMENT		
Stainless Steel 5 Valve Manifold, 'T' Type, Direct mount, T-Bar handle,c/w Drain/Vent	(Inlet) 1/2" Female NPT	(Outlet) Flange	1/4" Female NPT	316L

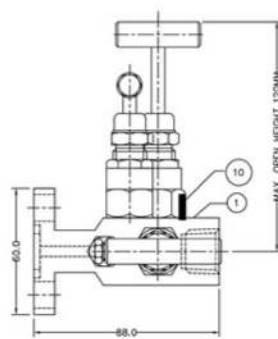
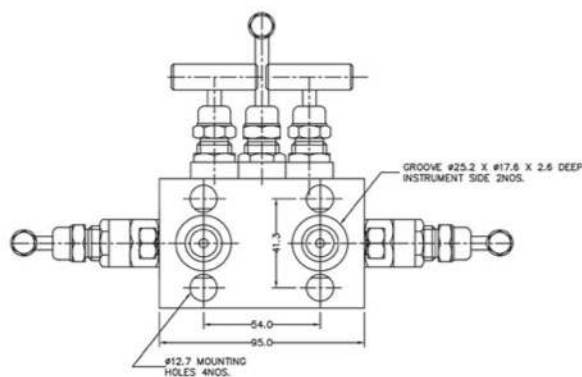
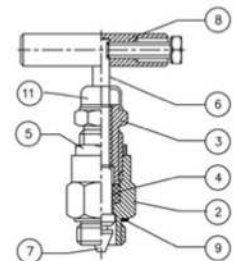
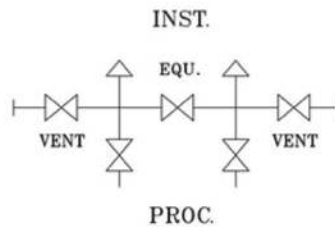
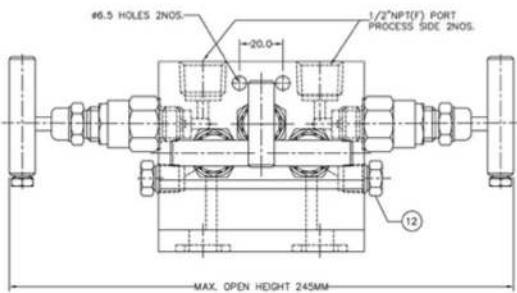

PART NO.	PART DESCRIPTION	MATERIAL	QTY
1	BODY	SS 316L	1
2	GLAND BODY	SS 316L	5
3	GLAND RETAINER	SS 304	5
4	GLAND SEAL	P.T.F.E	10
5	CHECK NUT	SS 304	5
6	SPINDLE	SS 316L	5
7	TRIM	SS 316L	5
8	HANDLE	SS 304	5
9	WASHER	S.S.	5
10	LOCK PIN	SS 304	5
11	DUST CAP	P.V.C.	5
12	DRAIN PLUG 1/4" NPT (M)	SS 316L	2

MATERIALS & TESTING

MANIFOLD BODY			
MATERIAL	BAR STOCK	FORGING	UNS
316L SS	ASTM A-276 ASTM A-479	ASTM A-276 F-316L	S31600

VALVE COMPONENTS			
VALVE BODY	STEM / TRIM GLAND & GLAND WASHER	RETAINER	HANDLE
316L SS	316L SS	304 SS	304 SS

FLANGE MOUNTING COMPONENTS	
FLANGE O-RINGS	BOLTS
Polytetrafluoroethylene (PTFE)	304 SS

A Note on Safe Product Selection:

Customer to select suitable product type and size based on the application considering the overall system design.

For Safe, easy and trouble-free operation the customer must consider material compatibility, temperature and pressure ratings when selecting a product.



MATERIALS & TESTING

Gland Packing Materials

The standard packing and flange o-ring material for all Mac-Weld valves is Polytetrafluoroethylene (PTFE). The maximum operating temperature is 464°F (240°C). Graphoil packing is available for temperatures above 464°F (240°C).

Cleaning

Mac-Weld instrument valve and manifold components are cleaned during the manufacturing process. Upon final assembly and testing each valve manifold undergoes a final cleaning and drying.

Operating Pressure

The recommended operating pressure for stainless steel 316/ 316L is 6,000 psig (414 barg). The Maximum Allowable Working Pressure: 6,000 psig (414 barg) @ 38°C (100°F)

Testing

Mac -Weld valve manifolds are factory tested in accordance to the following standards:

MSS-SP-99		ANSI-B 16.34	
Test pressure at 25°C Room Temperature		Test pressure at 38°C (100°F)	
Hydrostatic	Pneumatic	Hydrostatic	Pneumatic
Body: 414 barg	Seat: 40 barg	Body: 630 barg	Seat: 7 barg
Seat: 150 barg			

